

CROWN OPTO S1

In front of you – technical information of the updated Crown OPTO S1 module. Crown OPTO S1 was a really good option for illuminating middle-range depth letters and light boxes, but now it is even better. We have equipped S1 with a better LED, resulting in increased life time to L70 45 000 h, hence granting 5 years 24/7 warranty. Crown OPTO S1 – a great option for middle-range depth projects when economical, although quality solution is needed.

Application

- Channel letters signs and light boxes
- Recommended depth 50 – 120 mm

Features & benefits

- Compact design
- Efficiency up to 107 lm/W
- IP67 protection class
- White, red, green and blue colours are available
- 5 year warranty



CROWN OPTO S1 technical information

General specifications

Supply voltage	12 VDC
Power	0.75 W
Recommended depth	From 50 to 120 mm
CC distance	200 mm
Binning	3 SDCM
Operating temperature	-30 °C ~ +50 °C
Storage temperature	-40 °C ~ +70 °C
Storage conditions	Relative humidity <60%
Certification	CE and RoHS compliant
IP class	IP67
Lifetime	L70 45,000 h
Warranty	5 years (24/7)*

* Warranty is applied only and if storage, mounting and maintenance conditions, stated in the installation guide, are followed.

Light distribution graph

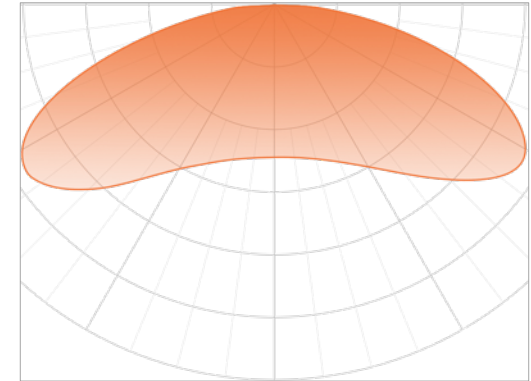

Beam angle: 160°

Dimensions

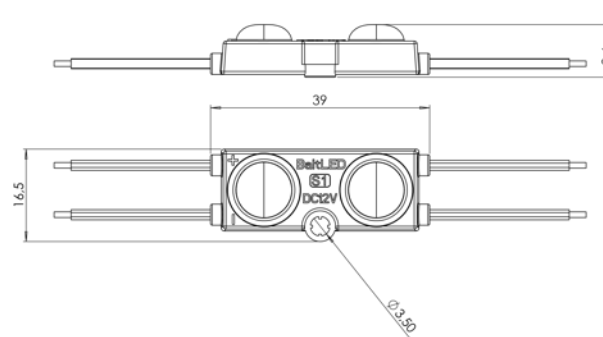

Ordering information

SKU	Luminous flux, lm	Colour temp., K	Power, W
BMP-S1-O2UH160CW651	80	6600	0.75
BMP-S1-O2UH160CW652	80	6500	0.75
BMP-S1-O2UH160RC	30	624 – 626	0.75
BMP-S1-O2UH160GC	50	473 – 475	0.75
BMP-S1-O2UH160BC	13	535 – 538	0.75

Ordering quantity

Chain: 50 pcs	(net weight: 0.385 kg)
Bag: 100 pcs	(net weight: 0.820 kg)
Box: 1000 pcs	(net weight 8.7 kg)